

Wyciskanie siedząc

R37-UBX-247B



14+



1



0,5m



1 = 0,9m 2 = 0,8m 3 = 1,45m



Użytkownik kontroluje siłę ćwiczeń przez siłownik hydrauliczny.

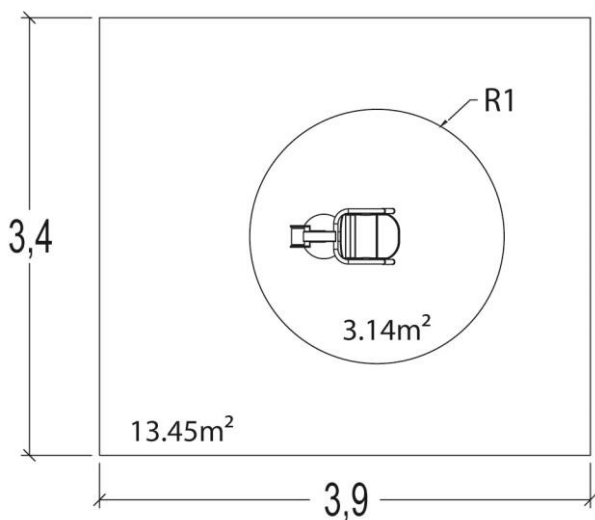
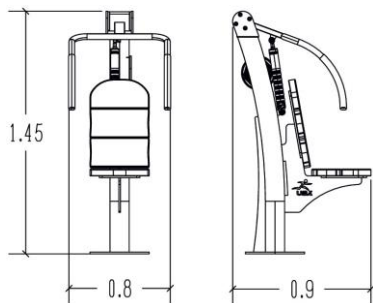

STYMULOWANE MIĘŚNIE



WYKONYWANE RUCHY

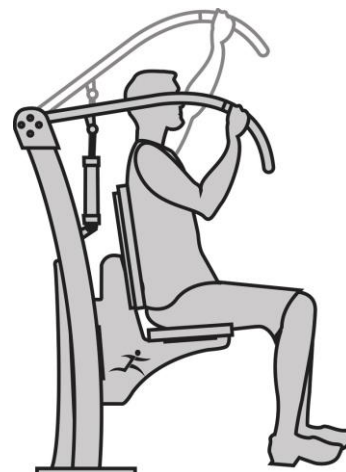

CERTIFICATIONS

